

GASLIGHT GAZETTE

S E P T E M B E R 2 0 1 9

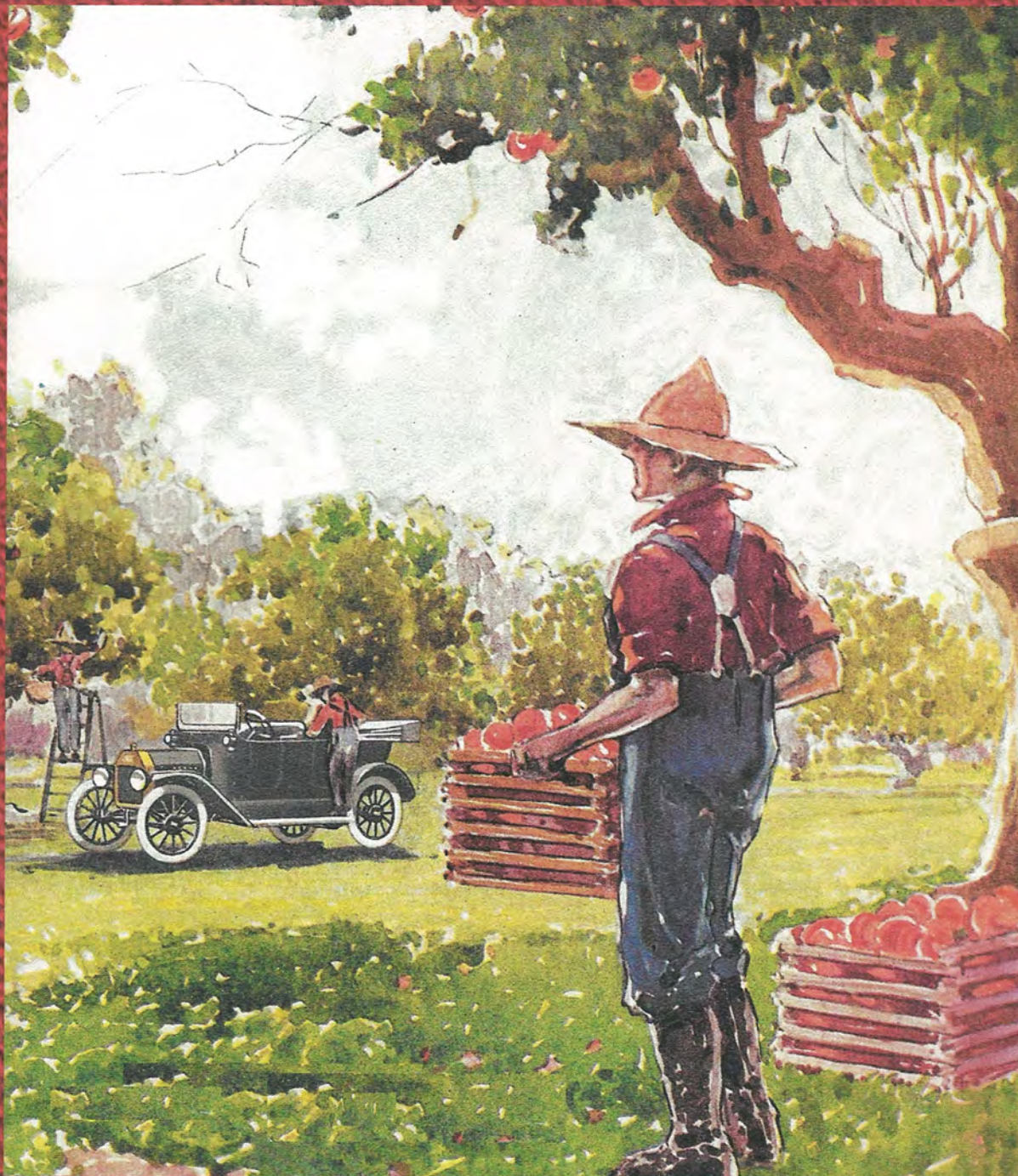

BAY AREA HORSELESS CARRIAGE CLUB



GASLIGHT GAZETTE

A PUBLICATION OF THE BAY AREA HORSELESS CARRIAGE CLUB



S E P T E M B E R 2 0 1 9

2019 BOARD OFFICERS & MEMBERS

Board Chair



Ed Archer
1807 East Avenue
Hayward, CA 94541
karened4@att.net
510-581-4911

Member



Johnny Crowell
2874 Fieldview Ter.
San Ramon, CA 94583
jcrow22006@aol.com
925-963-5835

President



Ed Harley
167 Clover Hill Ct.
Danville, CA 94526
epharley@pacbell.net
925-838-7460

Member



Vince O'Brien
241 Via Barranca
Greenbrae, CA 94904
vobrien241@gmail.com
408-302-7030

Vice President



Christine Crowell
2874 Fieldview Ter.
San Ramon, CA 94583
hccboss@aol.com
925-963-5825

Member

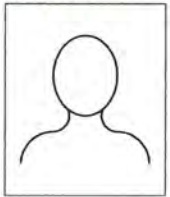

Vacant

Secretary



John Morrison
1450 Grand Ave.
Oakland, CA 94610
johnpmorrison@sbcglobal.net
510-407-0708

Gazette Editor



Mark Cerruti
256 La Questa Dr.
Danville, CA 94526
cerrutidesign@comcast.net
925-639-9770

Treasurer



Whitney Haist
12 Sunrize Hill Rd.
Orinda, CA 94563
haist2@comcast.net
925-899-4912

~ CLASSIFIED ~

"How should I class in my accounts the money I have spent in auto-speeding fines?"

"Why not list them under the head of 'running expenses?'"

2019 COMMITTEE CHAIRS

Tours & Events Co-Chairs	Johnny Crowell Vince O'Brien	925-963-5835 415-302-7030	jcrow22006@aol.com vobrien241@gmail.com
Membership & Media Chair			
Web Master	Mark Wheeler		mark@tonedeafdesign.com
Hospitality	Kaaren Brommer Pam Johnson	510-538-1795 650-228-4222	kebrommer@aol.com dearlj@sbcglobal.net
Sunshine	Kaaren Brommer	510-538-1795	kebrommer@aol.com
Nuts & Bolts	Whitney Haist Gerald Robinson	925-899-4912 510-486-5769	haist2@comcast.net gefrobinson@yahoo.com

The BAY AREA HORSELESS CARRIAGE CLUB (BAHCC) was founded in 1951 by and for automobile antiquarians dedicated to the preservation of pre-1916 motor vehicles. The BAHCC is one of numerous Regional Groups of the Horseless Carriage Club of America, (HCCA) which has 4500 members worldwide. HCCA membership is required of all active touring BAHCC members, but is not required for "Associate" members. New membership into our club is invited.

GENERAL MEETINGS: First Wednesday at 7:30pm, monthly, (*except July & December - no meeting*) at the Piedmont Community Hall, 711 Highland Avenue, Piedmont, California. April and November are Potluck dinners starting at 6:30pm. Guests are always welcome. Special presentations at meetings.

BOARD MEETINGS: Monthly, see Calendar for schedule. All members welcome.

ADDRESS: c/o President. **PHONE:** c/o President.

WEBSITE: www.bahcc.org

EDITOR'S NOTES:

Dear New Members,

On behalf of the entire Membership, I would like to welcome you to the Bay Area Horseless Carriage Club. I hope you'll find membership in the BAHCC as rewarding as I have. Please enjoy this latest issue of the *Gaslight Gazette*!

Our next official tour is the "Pilgrim's Picnic," coming up late November. In the meantime, September 22nd is *Antique Autos in History Park*. It is a fantastic Car Show that should not be missed! Lots to see and do. Many BAHCC will attend with their cars.

I'm looking forward to meeting you at a future BAHCC meeting or event, and please feel free to contact me if you should have any questions.

Kind regards,

Mark Cerruti, Editor

p.s..... Please send me your stories, photos, for sale/want ads, etc. *Your feedback is always welcome!*

The GASLIGHT GAZETTE is published 11 times per year, with one issue for the months of July and August. Permission to reproduce articles is granted provided credit is given to the original source.

On the Cover; *Ford Times*© October, 1916
Artist; *unknown*

President's Letter

Tours

The **July 4th Parade and BBQ** was a big success. Thank you, John and Carolee Morrison.

The **July 21, Danville Car Show & Tour** was also a big success. Nine car owners and guests, on a beautiful Sunday, enjoyed this newest BAHCC Tour. Check out the article and photos in this Gaslight Gazette. Thank you, Vince, the Tour Chairman.

An Update on our New Member's Campaign.

To recap; On June 18, we sent prospective members in Northern California a copy of our June Gaslight Gazette plus a cover letter telling the BAHCC story and asking them if they desire to become members. On July 5, we sent a second mailing to the same prospects, inviting them to the July 21 Danville Car Show & Tour and to the August 7 Club Meeting. So far, the campaign has resulted in **7 new members**. On August 23, we will send a third mailing to the same prospects, giving them one final reminder of the benefits of becoming a BAHCC member. Mark Cerruti and I worked as a team on this campaign. Thank you, Mark.

Your 2019 Membership Directory

On July 26, we mailed each member of the BAHCC a copy of the 2019 Membership Directory. Creating this directory was a very challenging project. Mark Cerruti and I worked as a team to make this happen. Thank you, Mark.

Sharpsteen Museum

On July 31st, the BAHCC exhibit at the Sharpsteen Museum in Calistoga titled 'Life in the Slow Lane, Brass Era Cars' ended. Don Azevedo conceived the idea; The Schwartz family superbly executed the idea. In talking to the Docents at the museum, they were most excited to share the fact that the museum hosted many class outings of local school children. The children loved our exhibit and were most engaged. To educate the next generations about our hobby is one of our missions. A job well done by all.

Hats Off Tradition

At the September 4th Club meeting, we will honor Bill and Kaaren Brommer. Carolee Morrison will again be the chair of the evening. Don't forget to wear your hat, and be prepared to tell stories about when, where, and how Bill and Kaaren Brommer have helped this club and its members.

2020 BOARD Member Nominees

At the November Club Meeting, the membership will elect new BAHCC Board Members. If you wish to become a member of the BOARD, please talk to any BOARD member about our nomination and election process. It is your club. Get involved.

Happy Touring

Ed Harley

Danville Car Show & Tour

July 21, 2019

It was a weather-perfect day for participants of the *Danville Hot Summer Sundays Car Show*. Show Organizers were elated to include (gratis) our brass automobiles in the show, reserving the middle of downtown, allowing the BAHCC autos to parade in at the very last minute. After enjoying the crowd for a couple hours and having a bite to eat, the old machines fired-up, and sped away. The cars toured the country-side for a short while, convening



George Teebay's 1918 Pierce Arrow



Vince O'Brien's 1909 REO



Ed & Carolyn Harley's 1910 Buick



Johnny & Chris Crowell's 1914 Simplex

Photos by
Ed Harley

at a scenic park in Alamo. Tourists enjoyed cake & ice cream in the serene surroundings, then headed home.

Special thanks to Vince O'Brien & Ed Harley for making the tour a success.

Plans are already in the works for next year. Don't miss it! *Editor*

PARTICIPANTS

Vince O'Brien & Carol Graves . . . 1909 REO
 Ed & Carolyn Harley 1910 Buick
 Paul Chapot 1912 Overland
 Brian Harlamoff & Max Neary . . 1913 Ford
 Bill Hund & Mark Cerruti . . . 1914 Ford
 Johnny & Chris Crowell . . . 1914 Simplex
 Guests; Anthony Radzanowski
 & son Jack 1915 Ford
 Guests; Jeff & Sandra Schier . 1916 Hudson
 George Teebay & Ann . .1918 Pierce Arrow



Paul Chapot's 1912 Overland



1909 REO



Mark Cerruti & George Teebay



Carol Graves & Vince O'Brien preparing the treats!



19th Annual

"The largest annual antique auto show in the West"



Antique Autos in History Park

Sunday, September 22, 2019

11:00 AM to 4:00 PM

History Park, 635 Phelan Ave.

San José, CA . 95112

Presented by the Santa Clara Valley Model T Ford Club

&

History San José

- Period-Correct Pre-1946 • Antique Autos • Antique Trucks • Antique Motorcycles**
• Antique Bicycles • Antique Fire Equipment • Early Day Gas Engines
• Historic Buildings • Handcraft Demos • Antique Collectibles • Trolley Rides
• Dixieland Band • Vintage Clothing Recognition • Children's Activities

Food Available

& Ice Cream by O'Brien's Cafe

www.scvmtfc.org

www.historysanjose.org

A. J. Greenberg

GREENS CAUGHT SPEEDING?



While on their way to the 4th of July Parade, Rich & Ellen Green were pulled over by the law, and issued a citation for speeding, so says an unreliable source. A more reliable source reported that they simply had some trouble with their Model T, and the Officer was kind enough to stop and help.



The "Autoface."

Insures autoing in comfort. Protects face and ears from wind, dust and cold. Prevents sunburn, chapped face and lips. Close fitting and comfortable—on or off in a second.

A "tailor-made" nose provides fresh air and prevents fogging of the lenses. A convenient



mouth opening with self-closing flap, permits smoking and expectorating. Equipped with imported French goggles, with lenses of especial toughness, mounted on gauze extensions that prevent perspiring and are collapsible.

Perfectly sanitary. Can be washed like a pocket handkerchief by slipping out the goggles.

Our Cash Price	Not Prepaid	Prepaid
Poplin Cloth.....	\$1.50	\$1.54
Broadcloth.....	2.00	2.04
Cravenetted Silk.....	2.50	2.54
Light Weight Dust Proof Silk.....	3.00	3.04

FREE CAR SHOW. BRING YOUR CAR!

East Bay Swap Meet Collector Cars & Parts

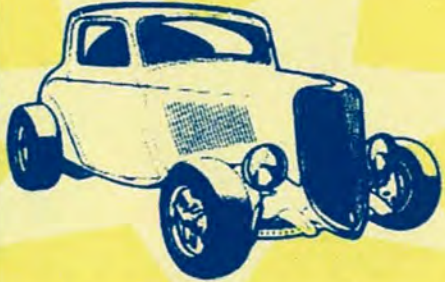

**Saturday, Oct 19, 2019
6:00 am to 3:00 pm**

Early vendor check-in and set-up Friday, ~~May 3~~ at 3:00 pm

**2151 Ferry Point #77
Alameda, CA 94501**

For more information or vendors
email: stroh32@hotmail.com
Call: Mark 510-432-1532

THIS EVENT IS HOSTED BY:



WHAT A DEAL!
20' x 20' stalls
are \$40.
Car for sale stall
\$30 each.

FREE ADMISSION & PARKING

TO REGISTER: Send name, phone, email, and check to Alameda Naval Air Museum
2151 Ferry Point #77, Alameda, CA 94501 • Day of meet phone ANAM 510-522-4262

East Bay Swap Meet Registration Form

Print: Name _____

Address _____ City _____ State _____ Zip _____

Phone Number (____) _____ Email _____

Signature _____

Number of Spaces for swap sale _____ x \$40 = \$ _____ **Day of Swap Meet –**

Number of Spaces for car sale _____ x \$30 = \$ _____ **Cash Only**

TOTAL _____

Make check payable to: Alameda Naval Air Museum, 2151 Ferry Point #77, Alameda, CA 94501

Deadline for reservations is April 29, 2019

I hereby release the Golden Gate Regional Group #1 of the Early Ford V-8 Club of America, Alameda Naval Air Museum, and City of Alameda, their officers, members, directors, agents, representatives, its employees or anyone else connected with the management or presentation of this event of any form of known or unknown damages, injuries, losses, judgment and/or claims from any cause whatsoever that may be suffered by an entrant to his or her person or property and all employees from any and all liability of personal or public property damage resulting from my participation in the event known as East Bay Swap Meet. I am over the age of 18. If not, a parent or legal guardian signature is required.

MONTEREY HISTORIC AUTOMOBILE RACES

Ed Archer, once again, competed in the Laguna Seca Historic Races, that took place in mid-August. "Ed was in great form!" reported Jon Alf.

photos by Jon



DEAR OLD LADY (having a lift—her first motor ride—as chauffeur signals a turn). "Look here, young man—you keep both hands on the wheel. I'll tell you when it begins to rain."

Photo Caption Contest Results

Congratulations to **Whitney Haist** for submitting the Winning Entry! Whitney will receive a \$20 Gift Certificate to Starbucks for his effort.

Thanks to all who participated. . . . Mark

"If there are twenty horses in there, what comes out of that little pipe in the back?"

"This will destroy the Human Race."

Allison Girzadas (age 14)

"OMG!"

Ed Harley

"I think it has the wrong sidelights."

Bill Cassidy



"Is this an Iron Horse?"

Grace Girzadas

"There are twenty of us under that hood?"

Whitney Haist

"Why do they measure the power of a horseless carriage as horsepower?"

Carolyn Harley

"Comment la monte-t-on?"

("How do you screw it?")

Bernard Metais

"I wonder if those seats are stuffed with horsehair?"

Doug Durein

"Why do humans name a product based upon what the product does not have, such as this horseless carriage?"

Carolyn Harley

"I can safely transport my drunken owner home. Can this horseless carriage do that?"

Carolyn Harley

The Thomas B. Jeffery Company
Main Office and Works, Kenosha, Wisconsin

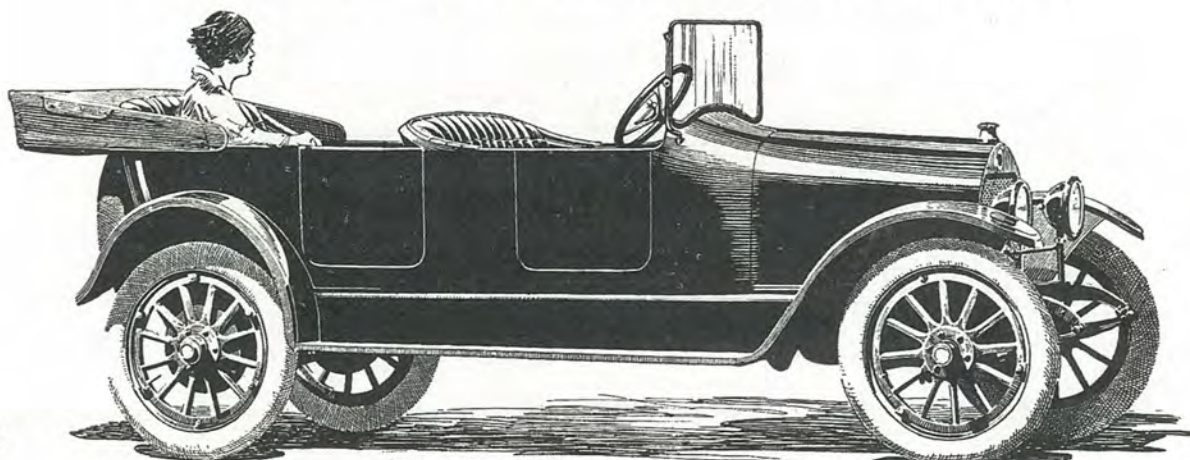



Courtesy of Johnny Crowell



Executive and Sales Offices:
DETROIT, MICHIGAN



R-C-H "TWENTY-FIVE" \$900

Long Stroke Motor, Big Roomy English Body, Center Control, Left Hand Drive, Every Necessary Accessory—And a Wonderful Economy Record.

Five Passenger Touring Car, 110" wheelbase, \$900 f.o.b. Detroit
Two Passenger Roadster, 110" wheelbase. 900 f.o.b. Detroit
Three Passenger Coupé, 110" wheelbase. 1300 f.o.b. Detroit

R-C-H CORPORATION

100 Lyncaste Street

DETROIT, MICHIGAN

The Pilot

"The Car Ahead"

Three Great Models. Pilot 40, four-cylinders, 4½x5. Brake test 53 horse power. 120-in. wheel base. Price, \$2,000. Pilot 50, four-cylinders, 4½x6. Brake test 59 horse power. 126-in. wheel base. Price, \$2,250. Pilot 60, six-cylinders, 4x6. Brake test 67 horse power. 132-in. wheel base. Price, \$2,500.

The Car Without a Mechanical Defect

Teetor "T" Head Motors, full floating rear axles, Brown-Lipe differential, Warner transmission, Eisemann Magneto, Stromberg Carburetor, handsome jewel bodies with ventilating windshield. Completely equipped with every convenience and comfort. Dynamo electric lighting and electric starter (Gray & Davis system), power tire pump. We have the greatest agency proposition in the United States. Write for our beautiful art book showing cars in detail.

PILOT CAR SALES CO.

Richmond, Indiana

MARMON

"The Easiest Riding Car in The World"

MARMON "32"

Four cylinders, 32-40 h.p., 120-inch wheel-base, electric starting and lighting system, left-hand drive, center control, nickel trimmings, with newest body types to meet every requirement and corresponding equipment—

\$2,850 to \$4,100

MARMON "48"

Six cylinders, 48-80 h.p., 145-inch wheel-base, electric starting and lighting system, left-hand drive, center control, nickel trimmings, with body types to meet every requirement and corresponding equipment—

\$5,000 to \$6,350

Detailed Information on Request.

Nordyke & Marmon Company
Indianapolis (Established 1851) Indiana



"Sixty Years of Successful Manufacturing"





BAHCC Club Meetings, Events and Tours Calendar

Meetings and Events Managed by: Ed Harley, President. eparley@pacbell.net 925-997-7710

Christine Crowell, Vice President. hccboss@aol.com 925-963-5825

Tours Managed by: Johnny Crowell, co-chair. Jcrow22006@aol.com 925-963-5835.

Vince O'Brien, co-chair. vob_low@comcast.net 415-302-7030

Month	Date/Day	Events	Speaker/ Special Event
Sep 2019	Sep 4 Wed	Club Meeting	<p>'Hats Off Tribute' to Bill and Kaaren Brommer</p> <p>Kaaren and Bill Brommer joined the club in 1998. For the past 20 years, they have been leaders (Kaaren was club President in 2010) or super-active followers. We will have an open microphone, encouraging anyone to share a story about when Bill did this or when Kaaren did that. We will conclude the evening by all tipping our hat, saying thank you to Bill and Kaaren for all they have done for the BAHCC. Carolee Morrison will be the moderator for this celebration.</p> 
	Sep 18 Wed	BOD Meeting	Harley's Home - 7:30 PM
Oct 2019	Oct 2 Wed	Club Meeting	<p>After the formal Club meeting, we will have unstructured member-to-member car-talk.</p> 
	Oct 16 Wed	BOD Meeting	Cerruti's Home - 7:30 PM
Nov 2019	Nov 6 Wed	Club Meeting	<p>Fall Potluck Dinner & Hobbies/Collections Night</p>  <p>Also: Member Appreciation Night; BAHCC 2020 Board Member Nominations and Membership Vote</p>
	Nov 11 Wed	BOD Meeting	Dinner
	Nov 29 - Fri	Tour	3rd Annual Pilgrim's Picnic by The Schwartz Family
	Dec 14 Sat	Joint Meeting	Holiday Party Board Member Inductions



Non - BAHCC events that may be of interest

September 8	Gatsby Summer Afternoon	Oakland, CA	gatsbysummerafternoon.com
September 22	Antique Autos in History Park	San Jose, CA	Allan Greenberg allang@pacbell.net
September 28	Ironstone Concours d'Elegance	Murphys, CA	ironstoneconcours.org
September 29	Turlock Fall Meet	Turlock, CA	springfallturlock.com
October 9 - 12	Hershey Swap Meet	Hershey, PA	hershey.aaca.com
October 19	Alameda Swap Meet	Alameda, CA	Mark: 510-432-1532 stroh32@hotmail.com
January 25 & 26	Turlock Swap Meet	Turlock, CA	turlockswapmeet.com

Contact the Editor to add a pre-war auto-related event to this Calendar

Parlez-vous Français?

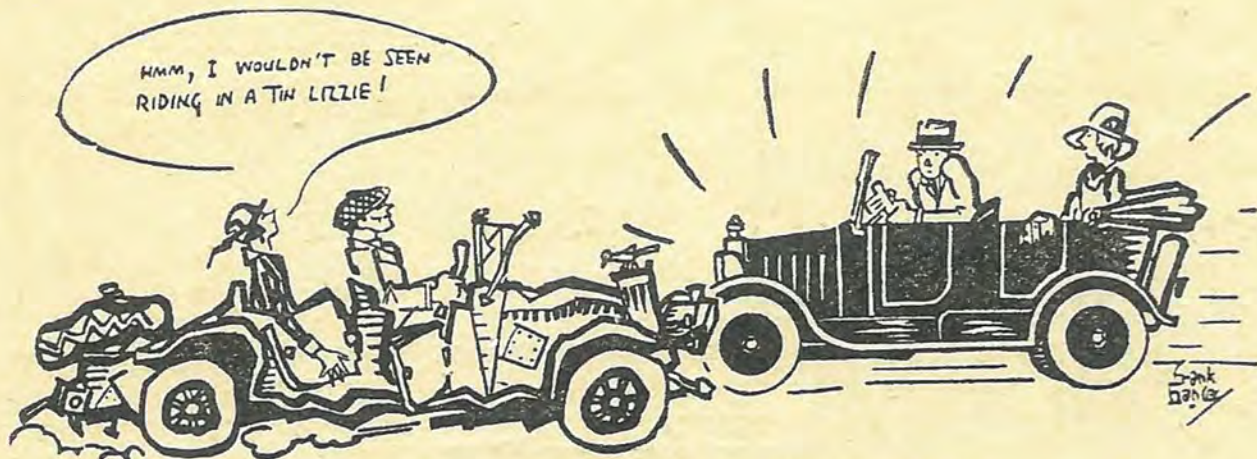

IL N'Y A RIEN DE TEL QU'UNE FORD
— C'est égal, je ne voudrais pas que l'on me voie dans une voiture
en zinc!
(Judge, New-York.)

See next page for translation



BACKING OUT A BROKEN STUD.
(Fig. 399.)

Recently a repairman while working under a car twisted the head off one of the crank case studs. The stud was well set and could not be removed. Taking a drill he made a hole as large as possible without striking the threads, drilling into the centre of the stud. He then took a one-half-inch worn out square file and ground the teeth from it, tapered the end out to one-eighth inch square, making the taper about one-eighth inch to each inch. This done he drove the file into the hole and getting leverage with a light monkey wrench the broken stud was easily removed.

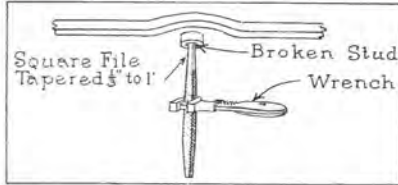

Fig. 399.

age by immediate repair. The accompanying sketch shows a very satisfactory piece of equipment that should be carried in every tool box and which is easily made.

This clamp can be placed upon the spring after the body of the car has been jacked up and it will render sufficient strength to the disabled spring to allow driving the car to a repair shop.

RUBBER MAT FASTENINGS.
(Fig. 400.)

The many who own Ford cars know the annoyance of having the rubber floor mat wrinkle and slide about, many times slipping around the speed pedals, where if becoming jammed in an emergency is liable to cause serious accident. As seen in the illustration this suggestion will be met with favor by the majority of Ford owners.

The mat should first be put in place, then tacked at regular intervals with a bead or button head heavy tack, after which the outside ends of the mat can be cut and notched with a pair of scissors, whereupon it will be found that thereafter the mat can easily be removed for repairs beneath the floor boards and will not wrinkle or look unsightly.

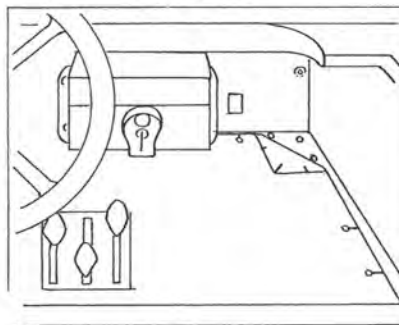

Fig. 400.

NOVEL WINDOW DISPLAY.
(Fig. 401.)

A mechanical device for window display if ingeniously constructed and bearing a point of mystery as to the source of its power, always proves effective in attracting the eye of the public and fixing their attention to the window, as well as fixing their minds on the name of the firm employing such a feature.

A square or circular hole is cut in the window flooring and a sheet of glazed glass inserted. Beneath the glass is a shaft to which a pulley and a round piece of board are attached. Upon the board are nailed four magnets at regular intervals and a belt running from the pulley to a small portable motor revolves the whole. The glass may be painted and scenery attached to imitate an automobile race track or circular road and four toy motor cars placed in position. The entire device is extremely simple to make and is very interesting to watch.

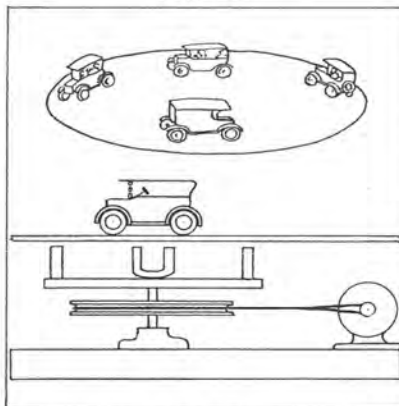

Fig. 401.

FIXING THE SPARK.

There is more science in the proper handling of the spark control lever than in the handling of the throttle, for the power, speed and gasoline consumption is to a great extent dependent upon the proper advance or retardation of the spark. It will pay one to spend a little time on a few experiments to determine the best spark setting for idling, power and speed on the lever, and when the different points are found, marking them. Select a hill for the experiment and with the throttle kept in one position run the car up the grade with the spark lever set at different positions a number of times until the hill is negotiated with the least engine effort. Then mark this point by screwing a small piece of tin in the shape of an arrow to the quadrant. In a similar manner find the best adjustment for low speed.

TEMPORARY REPAIR ON SPRING.
(Fig. 402.)

Quite often when on the road a car will break the top leaf of a spring. In most cars the top leaf of the spring has the most weight upon it, and it is therefore, important to prevent further dam-

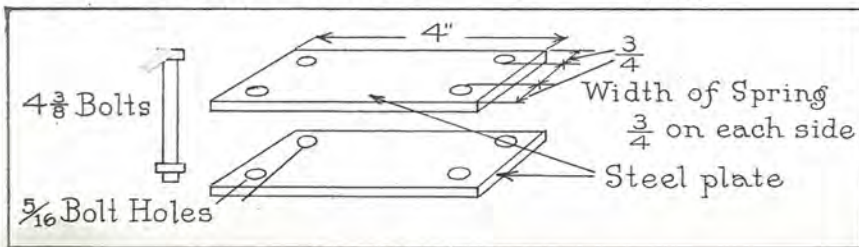

Fig. 402.

Parlez-vous Français?

Passenger in shiny new Ford — "There's nothing like a Ford."

Passenger in old car — "It's equal, I wouldn't want to be seen in a Tin Lizzie."

Welcome!

New Members

Evo & Darlene Coelho
Brentwood, CA

Sheldon Donig
San Anselmo, CA

James Farber
Yorkville, CA

Colin & Ellen Feichtmeir
Los Gatos, CA

Gary & Wendy Mills
Fremont, CA

Jim & Margie Pappakostas
Vallejo, CA

Don & Lillian Ritchey
Modesto, CA

Marvin & Joy Scott
Turlock, CA



Hospitality Calendar

Dessert Sign-ups

September	Ed Harley
October	Carolee Morrison
November	Potluck - By alphabet, check Gazette
December	Holiday Party - Catered
January 2020	
February	<i>Your name here!?</i>
March	
April	Potluck - By alphabet, check Gazette
May	
Contact Pam Johnson or Kaaren Brommer to Sign-up!	



Wheels can be thrown out of balance by a buildup of wheel ants. Protect your car's smooth ride with weekly applications of automotive grade insecticide.

Courtesy of Whitney Haist

Happy Birthday!

Sheldon Donig	Sept 4
Gary Mills	Sept 8
Ellen Feichtmeir	Sept 9
Max Neary	Sept 12
Mike Lawrence	Sept 14
Gerald Robinson	Sept 16
Lee Gularte	Sept 20
Donna Jones	Sept 23
Jean Boyden	Sept 25
Jon Eugenio	Sept 30

Happy Anniversary!

Mark & Veronica Cerruti	Sept 6th, 2003
Layden & Jean Butler	Sept 20th, 1986
Don & Joyce Azevedo	Sept 21st, 1974
Whitney & Diane Haist	Sept 27th, 1969

HCCA NATIONAL NEWS



Re: 2020 National Convention, New Registry, HCCA Facebook Moderator, CCA Website, HCCA Display, Regional Outreach, Marian Welsh Award
Issue: 2019-07-08 #04

- **2020 HCCA National Convention, Tour and Board Meeting** – Don Plumb has started planning the 2020 HCCA convention for next year – So far the plans are ...

Date: April 19 – 22, 2020

Location: Stateline, NV at Lake Tahoe

This event will follow a Bakersfield tour and swap meet (April 15 – 18). When more details for the event are known, we will pass the information on to the members.

- **New Registry** – The HCCA approved the re-launch of The Cole Motor Car Registry, president, Kevin Fleck, of Canton, MI; (269) 830-6174, kfleck@outlook.com; Website www.Colemotorcarregistry.com. The previous organization stopped functioning in 2010.

- **HCCA Facebook Moderator** – With the desire to improve communication, there needs to be better coordination of the club appearance on Facebook. Chris Paulsen volunteered and was approved to be the HCCA Facebook moderator.

- **Internet / Web site** – Brad reported to the board that the website in the offseason for North America had 43,559 visitors in December 2018. The average number of visitors daily is 1,605. Were you one of them? The number of pages visited per visit was 3.92. Classifieds attracted 47,001 visitors. The Discussion Forum attracted 17,080 views. The Club Store was visited 826 times. Calendar was visited 826 times and National News was visited 300 times...

Give a friend a ride and encourage them to join HCCA. Remember new members can take advantage of a special introductory price of \$19.15.

- **HCCA Museum Display** – At the Feb 2019 Board meeting it was reported that between May 8, 2020 and Oct 11, 2020 the HCCA will have a club display at the AACA Museum in Hershey. The display will be transportable and transferrable to a future display site. This is an

effort to get the word out about the club and who we are and what we do.

- **Regional Group Outreach Project** – Under the direction of Mike Reid, the HCCA directors contacted local Regional Groups and Affiliated Registries to determine their “status”. If a local club needs help, HCCA would like to try and help. This is part of an effort to better know and help the local organizations. The goal is identify charters that are in areas that are no longer serviced. During the review the committee identified 7 Regional Groups that are on “life support” and 5 that are inactive and not in compliance with national rules.

- **Long Range Strategic Planning** – Bob Ladd and Chris Paulsen ... Discussed the possibility of establishing a relationship with the Gilmore museum in MI. No details are known yet.

- **Marian Welsh Award Nominations** – Members are asked to send to Andy Wallace, Award chairperson, at the HCCA office recommendations of candidate(s) for the 2019 Marian Welch award that are to be considered by the Board of Directors. The Qualifications are...
 - > **Member** for minimum of 10 years,
 - > **Active involvement** at the Local and National levels,
 - > Held different **Leadership Positions**,
 - > Examples of demonstrated **Outstanding Service**
 - > Has shown **Dedication, Consistent, Continuing Service** over a period of time ...

For the best consideration, nominations should include the following information about the nominee(s) ... *Membership Length; Leadership positions held, Activities, Amount and types of Service at the local and National Levels, Effort to promote club values and Helping of others / mentoring.*

Carlton Pate / anpcop@aol.com

Board Associate who represents the members ...

HCCA NATIONAL NEWS



Re: Hershey 2019, Long Range Planning, 2020 Convention, HCCA Website, Marian Welsh Award Nominations Deadline.

Issue: 2019-08-16 #05

- **Hershey 2019** –

The fall *HCCA Board of Directors meeting* is scheduled for October 8, 2019, 6:30 PM at the Hershey Italian Lodge, 128 Hillcrest Rd, Hershey, PA; open to any HCCA Member. Before the meeting 5:00 PM to 6:00 PM there will be a HCCA cold buffet for \$20 per person. If you want to attend buffet, contact Bob Ladd.

The *HCCA tent* will be located at RWO 30 from Wed. Oct 9, 2019 to Fri. Oct 11, 2019. The HCCA barbecue is at noon on Fri. Oct 11, 2019.

If any local HCCA organization wants to hold a meeting at the Hershey space, they should contact the HCCA office to get a time reserved.

- **Long Range Strategic Planning** – Bob Ladd and Chris Paulsen ... Discussed the possibility of establishing a relationship with the Gilmore Museum in MI. When details are known we will keep the members advised.

- **2020 HCCA National Convention, Tour and Board Meeting** – Don Plumb has started planning the 2020 HCCA convention for next year – So far the plans are ...

Date: April 19 – 22, 2020

Location: Stateline, NV at Lake Tahoe

This event will follow a Bakersfield tour and swap meet (April 15 – 18). When more details for the event are known, we will pass the information on to the members.

- **HCCA Web Site** – HCCA Board of directors has developed a list of requirements that the organization needs for the digital world. There will be a Member Log status box that will allow a Member access to their profile information while Guest views will be limited to selected areas. Roster information ... members will have the ability to search, update on-line and print contact information. Membership renewal will be available on-line to keep members current.

Added to the HCCA site will include a HCCA Member's Comment Forum to better identify and track service issues and resolutions. The hope is to give members access to a Gazette article index and access to other club documents.

- **Marian Welsh Award Nominations** – The deadline for the submission of nominees for the 2019 Marian Welch award is September 1, 2019. If a member has a candidate to nominate, the nominee name and information should be sent to Andy Wallace, Award Chairperson, at the HCCA office. To make the case for your candidate, the submission should include the following information ...

- > **Membership length** in HCCA,
- > The **Leadership Positions** held at the Local and or National level.
- > **Activities** they have attended, sponsored or led,
- > The amount, type, and examples of **Outstanding Service** at the Local and or National levels,
- > Effort to **Promote club values** and
- > **Helping of others** / Mentoring ...

Since this is the highest honor that can be given to a HCCA member, you need to present the facts to justify such a high honor ... A list of previous winners can be found in any HCCA Roster.

In the fall of 2019, the list of candidates and information received will be sent to the directors for their review. Each HCCA Director will then fill out a ballot with their choice of the best candidate ... The winner will be announced at the 2020 National Convention.

Carlton Pate / amcpop@aol.com

Board Associate who represents the members ...

BAHCC General Meeting Minutes from August 7th, 2019

In the absence of President Ed Harley, who was away on vacation, the meeting was called to order by acting President Whitney Haist at 7:32 p.m. at the Piedmont Community Hall. Eleven members were present (Whitney, the Archers, the Brommers, the Morrisons, the Johnsons, Tony Wollesen and Mark Cerruti. Also present was guest Gary Mills of Fremont, CA, who came to the meeting as a result of our recent letter and copies of our most recent newsletters plus a blank membership application that were sent out to potential members. He was introduced, has numerous vintage automobiles (including a 1906 Cadillac), and brought a dues check and a filled out membership application. (He explained that he is very active with the inclusion of antique cars in events that take place in Niles, CA.

Secretary John Morrison asked if there were any corrections or additions to the Minutes of the June 5th General Meeting (as printed in the August Gaslight Gazette) There being none, Kaaren Brommer moved and Mark Cerruti seconded that the minutes be approved as printed, and the motion passed.

Next was a discussion about a local longtime antique car parts dealer, Don Knopp, who passed away not long ago, and about what happened with all his old parts.

CARING ABOUT EACH MEMBER'S BRASS ERA CARS-
John Morrison reported that during the Fourth of July short tour after the parade, something broke in his Cadillac's rear driveline, luckily near his house. After the BBQ, the car was winched on his trailer, moved around the block to the back driveway, and was left there covered for a week while Carolee and John went to Oregon on vacation. Meanwhile, Tony came back and figured the problem was with the right rear axle. Once the Morrisons were back home, Tony W., Gerald R. and John took out the axle and saw that it would need to be replaced. This meant that a new one would have to be made unless we could find a spare one. John was very lucky in that the first person he tried, a friend from Ohio with whom he has traded Cadillac parts over the years, had one, and was willing to let John become its new owner, so the car should soon be repaired.

RECENT TOURS AND EVENTS--

July 21 was the Danville Summer Sunday Car Show and Tour. Several of our members reported it was very successful. We were given a choice location for our 10 or so cars present. Our cars were given lots of attention, and then we went on our own short but sweet tour and treats before heading home-- good time, good camaraderie!

Carolee Morrison reported all is set for the September "Hats Off" event in honor of the Brommers. Please don't forget to bring your hats!

UPDATE OF MARKETING CAMPAIGN FOR NEW BAHCC MEMBERS--

Mark Cerruti and pretty much everybody present felt quite happy with how well it is going-- 7-8 new members so far and perhaps more to follow. Ed Harley was not at the meeting, but it was noted that this was his initial idea, and that he, Whitney and Mark Cerruti all have worked very hard on this membership drive project.

Photo Caption Contest-- Mark Cerruti reminded that it ends on Friday, August 9!

Whitney thanked the Johnsons for bringing tonight's treats (and thank you, Whitney, for bringing the water and sodas).

Whitney brought a very interesting "whatzit" that turned out to be a sort of a bomb. Hopefully he will report on it again next meeting.

Sunshine Report--

Karen Brommer sent a sunshine note to John Bertolotti-- Tony Wollesen added that John had a bad fall causing seven fractures of one of his hips. Progress is happening but it is a serious injury involving serious pain.

Adjournment occurred at 8:24 p.m.

It was later mentioned that Doug Durein will be putting his 1903 Dyke up for auction soon. If interested, call Doug.

Respectfully submitted,
John Morrison, Secretary



MAYO SPARK PLUG PUMP

A simple and powerful pump adaptable for use on all cars from the smallest Ford to the largest Lozier. Instantly attached by substituting it for a spark plug. Pumps nothing but pure, fresh air. Inflates the tire in from 2 to 4 minutes. Built with metal rings like your engine and will last as long. Requires no attention other than an occasional drop of oil. Weighs only 2 1/2 pounds.

Furnished with adapters to fit any car, 12 feet of hose and connections. Price \$10.00. With Pressure Gauge, \$2.00 extra.

You can try it on your own motor before purchasing

The Mayo Mfg. Co.
51 E. 18th St. Chicago

\$10⁰⁰/₀₀

Peerless
The Car of Achievement

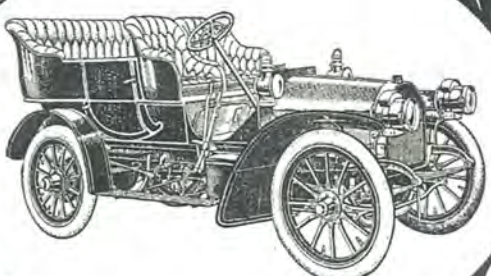

PEERLESS WON HILL CLIMB

at Worcester, Mass., May 25th, in the event for cars selling at \$3,000 to \$5,000, winning against five of the best known cars in that class.

The unusual difficulty of the climb and the full representation of cars in the event, make this victory one of the most noteworthy of the year.

For speed and power buy a Peerless.

Send for catalog.

The Peerless Motor Car Co.
 Lisbon Street, Cleveland, Ohio
 Member A. L. A. M.
 L. S. M. B. Co. Cleve.

BAHCC BOARD MEETING MINUTES

From August 21, 2019

Call to Order—President Ed Harley called the meeting to order at 7:35 p.m. at his home in Danville. Only three Board Members were present, President Ed Harley, Secretary John Morrison, and Gaslight Gazette Editor Mark Cerruti. That not being enough to constitute a quorum, there was no actual Board Meeting tonight, but simply some casual, good discussion.

For that reason, the following items are not to be considered "Minutes", but rather "Unofficial Notes" regarding items discussed, (and therefore not subject to the usual approval of minutes process.)

We read the minutes of the Board Meeting of June 19th as printed in the subsequent "Gaslight Gazette," and they appeared fine as printed.

Ed said he was very pleased about how all the parts of our activities on the Fourth of July had gone-- Piedmont Parade, after tour, and afternoon BBQ at the Morrisons.' He noted it was fun to see the Deco Belles' costumes and to have their cars join us in the backyard festivities. Attendance was excellent and camaraderie exceptional. Mark and John agreed, and John noted that the weather was also wonderful, as were the many good salads, desserts and side dishes provided by Carolee and her friends, BAHCC members present, and most of our guests.

We discussed the July 21st Danville Summer Sunday event we joined with this year for the first time. Ed said all of us who went had an excellent time, and he noted that the person in charge, Dave Miller, told him he was thrilled about our being there. He also formally invited us back for next year (third Sunday in July again).

Ed commented that with that invitation we now have at least four or five good events already lined up for next year.

We next discussed our recent Proactively Marketing for New Members Project, two mailings done already and one more coming up. So far it has led to seven new members, and we were very happy to step back and note that. It was agreed it has been quite an effort, but that it has been worth it.

Unofficial notes respectfully shared,

John Morrison, Secretary





MAISON DE VENTE

21, CHAMPS-ÉLYSÉES



L'ÉLÉGANCE - LA FORCE - LE SILENCE - LA SOUPLESSE
QUALITÉS DE LA VOITURE

HOTCHKISS

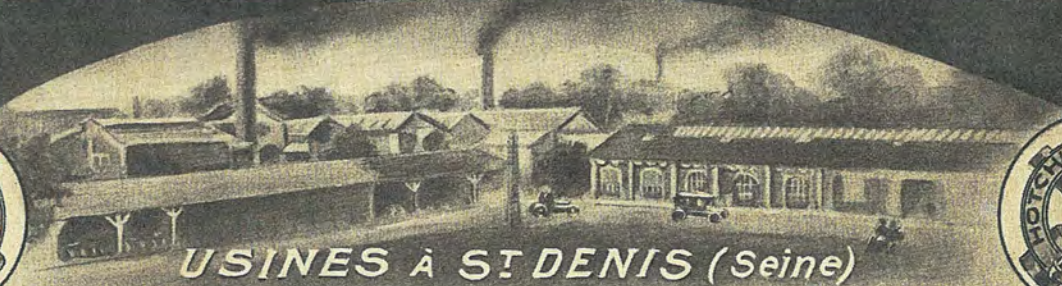

USINES À ST DENIS (Seine)