

GASLIGHT GAZETTE

NOVEMBER 2018



Special
SHARPSTEEN
ISSUE

FOR
STEADY
NERVES
DR. MILES'
NERVINE

15 miles
from
**GRANTS
GARAGE
&
Cyclery**
ST. HELENA

BEN
SHARPSTEEN



GASLIGHT GAZETTE

A PUBLICATION OF THE

BAY AREA HORSELESS CARRIAGE CLUB

N O V E M B E R 2 0 1 8



2018 BOARD OFFICERS & MEMBERS

Board Chair



Don Azevedo
3802 Briarcliff Dr.
Pittsburg, CA 94565
Imnuts4fords@comcast.net
925-301-5315

Member



Christine Crowell
2874 Fieldview Ter.
San Ramon, CA 94583
hccboss@aol.com
925-963-5825

President



Ed Archer
1807 East Avenue
Hayward, CA 94541
karened4@att.net
510-581-4911

Member



Johnny Crowell
2874 Fieldview Ter.
San Ramon, CA 94583
jcrow22006@aol.com
925-963-5835

Vice President



Ed Harley
167 Clover Hill Ct.
Danville, CA 94526
epharley@pacbell.net
925-838-7460

Member

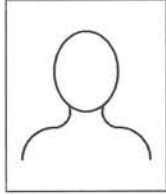

Secretary



John Morrison
1450 Grand Ave.
Oakland, CA 94610
johnpmorrison@sbcglobal.net
510-407-0708

Gazette Editor



Mark Cerruti
256 La Questa Dr.
Danville, CA 94526
cerrutidesign@comcast.net
925-639-9770

Treasurer



Whitney Haist
12 Sunrise Hill Rd.
Orinda, CA 94563
haist2@comcast.net
925-899-4912

~ TIMELY ~

Red — "Did you ever time yourself in your automobile?"

Green — "Yes; it took me an hour to start the blamed thing yesterday."

2018 COMMITTEE CHAIRS

Tours Chair	Johnny Crowell	925-963-5835	jcrow22006@aol.com
Web Master	Mark Wheeler		mark@tonedeafdesign.com
Membership	Don Azevedo	925-301-5315	imnuts4fords@comcast.com
Authenticity	Don Azevedo	925-301-5315	imnuts4fords@comcast.com
Hospitality	Kaaren Brommer Pam Johnson	510-538-1795 650-228-4222	kebrommer@aol.com dearlij@sbcglobal.net
Sunshine	Susan Durein	510-523-4993	
Nut & Bolts	Doug Durein	510-523-4993	dougurein@gmail.com

The BAY AREA HORSELESS CARRIAGE CLUB (BAHCC) was founded in 1951 by and for automobile antiquarians dedicated to the preservation of pre-1916 motor vehicles. The BAHCC is one of numerous Regional Groups of the Horseless Carriage Club of America, (HCCA) which has 4500 members worldwide. HCCA membership is required of all active touring BAHCC members, but is not required for "Associate" members. New membership into our club is invited.

GENERAL MEETINGS: First Wednesday at 7:30pm, monthly, (except July & December - no meeting) at the Piedmont Community Hall, 711 Highland Avenue, Piedmont, California. April and November are Potluck dinners starting at 6:30pm. Guests are always welcome. Special presentations at meetings.

BOARD MEETINGS: Monthly, see Calendar for schedule. All members welcome.

ADDRESS: c/o President. **PHONE:** c/o President.

WEBSITE: www.bahcc.org

EDITOR'S NOTES:

Dear Members,

Welcome to this Special Sharpsteen Issue! The opening of our exhibit, "Life In The Slow Lane," is just days away. I hope to see you there! If you can't make the opening, you must add a visit to the Sharpsteen Museum to your agenda.

Thanks are due to the Schwartz Family for taking on this endeavor, and to the members that have generously loaned their treasures. Much gratitude to the Sharpsteen Museum itself, for letting us share their wonderful museum.

I would like to extend a special thanks to Gail Sharpsteen for granting us permission to showcase her grandfather's artwork in this issue.

Mark Cerruti, Editor

The GASLIGHT GAZETTE is published 11 times per year, with one issue for the months of July and August. Permission to reproduce articles is granted provided credit is given to the original source.

On the Covers; *Stage Coach and Pope Hartford* © Artist; Ben Sharpsteen (1895 - 1980)

T'ain't rainin' here!

That's one of the big reasons we live here in California. Alright, we pay the big taxes, high cost of living, highest fuel prices, etc. etc. but,..... love the weather. Year around enjoyment with our automobiles. Karen and I just returned home from a Delta River tour. Driving the race car, no fenders, no windshield, drove there and back, a little brisk in the mornings but the rest of the day, to die for! And on the news I hear of the multi-day rain storms in Texas, rain and freezing in other parts of the U.S. etc. etc. Oh yes, I have to admit the grass is greener elsewhere..... That's because they get our share of inclement weather, before and after our mild winters.

Moving on to what I should be talking about, oh yes, the club! As you're aware, it's almost November already which means time to think of Thanksgiving and or more appropriately from my perspective, a new slate of club officers, which can mean new energy and enthusiasm. Not to discredit in any way our current management, as we currently have a smooth running organization thanks to our current well tuned board of directors and group of committee volunteers that have kept things rolling in a positive direction all year long. That said, it's time for change. Be sure to attend the November meeting where even though the nominating committee will present their recommendation for a new slate of officers, you'll have the opportunity to nominate the candidate of your choice and then vote in, a new slate of board of directors. And with new board members, I'm getting wind of some enthusiastic new ideas for an exciting 2019. Be prepared!

Don't forget though, 2018 isn't over yet. We still have the Sharpsteen Museum opening night on November 9th with our BAHCC special display. The Pilgrims Picnic Tour, day after Thanksgiving, and the Christmas Dinner in December, and who knows what else might pop up. In fact, if you have a car project that you would welcome some help on, get a hold of Doug Durein and let's do a Nuts and Bolts event at your place or arrange to bring it to Doug's museum garage in Alameda for a Saturday session, we're starving for another exciting challenge. Oh yeah, and don't forget that also at our next meeting is member appreciation night. What does that mean? Come and find out.

President, *Ed Archer*

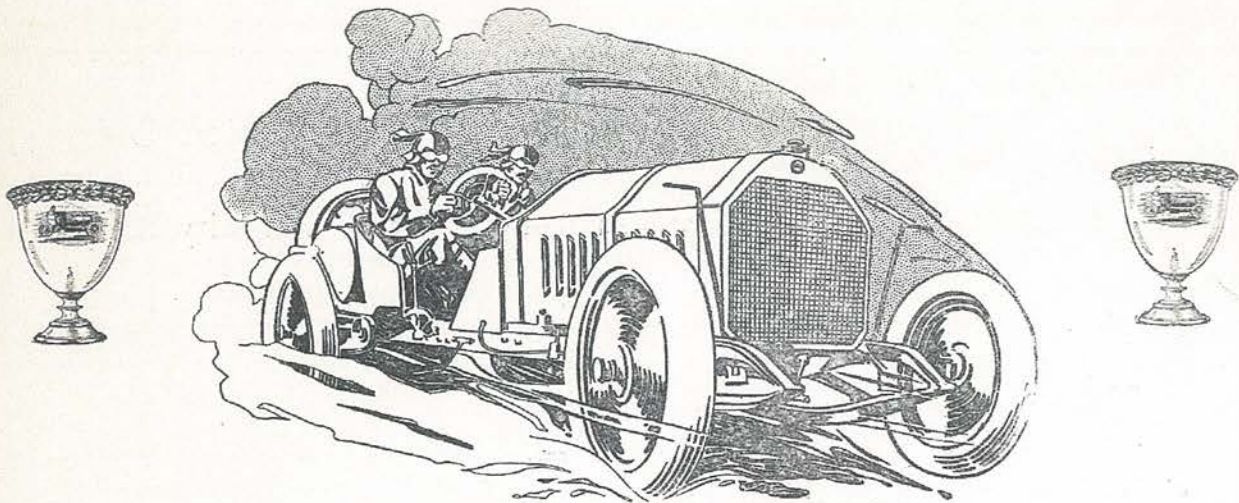

ALCO

Two Time Winner of the Vanderbilt Cup

Consistent, Powerful, Enduring, Silent

THE ANTI-FATIGUE CAR
"IT STAYS NEW"

American Locomotive Company

1886 Broadway, New York 1201 Michigan Ave., Chicago

Please Say You "Saw It in the AMERICAN MOTORIST," when Writing Advertisements



THE SHARPSTEEN MUSEUM PRESENTS

LIFE IN THE SLOW LANE

BRASS ERA CARS

PRE 1916



A UNIQUE EXHIBIT OFFERING A GLIMPSE INTO THE PERIOD OF
AUTOMOTIVE HISTORY FEATURING EARLY TRAVEL ITEMS,
BRASS AUTO ACCESSORIES, ADVERTISING ART, GAS
MEMORABILIA, FASHION, AND MORE. (NO VEHICLES)



EXHIBIT GENEROUSLY PRESENTED BY THE BAY AREA (CALIFORNIA) CHAPTER OF THE HORSELESS CARRIAGE CLUB OF AMERICA

EXHIBIT RUNS TO MAY 2019

Opening Preview Party
Friday, Nov. 9, 2018
5:30 – 7:00 pm



Light Refreshments
with Appetizers and
Accoutrements

1311 WASHINGTON STREET, CALISTOGA, CALIFORNIA • OPEN DAILY 11AM-4PM • 707-942-5911 • WWW.SHARPSTEENMUSEUM.ORG

FALL POTLUCK

November 7th, 2018

Piedmont Community Center 711 Highland Avenue, Piedmont

Set-up at 6:30 – Dining at 7:00

It's Potluck time again! Let's all come out for a delicious meal to share with other club members and friends.

FOOD INSTRUCTIONS:

MAIN DISH: K - Z

SALAD: A - C

DESSERT: D - J

The Club supplies coffee/tea soft drinks & Ham.

Secret Chefs prepare the Ham!

Please bring your own dishes, table service, glassware & decorations.

Remember to wear your name tag!

(No Auction)





PILGRIM'S PICNIC & BACKROADS TOUR

FRIDAY NOVEMBER 23, 2018

Calling all pilgrims... with leftovers:

Join us for this Schwartz family event, the Pilgrims Picnic. Pack up your picnic basket with the remains of the previous day's feast and meet us under the Martinez trestle staging area at the intersection of Alhambra Ave. & Highway 4 at 11am. We will follow the "turkey path" through scenic pastoral backroads, to a yet to be determined picnic venue, for our pilgrim-style lunch in nature.

You may bring dessert to share, if you like.

Should weather be un-cooperative, we will convene indoors at 406 Ward Street, Martinez and picnic among the car collection.

Planning to join us?

Please let us know:

Norman and Adria Schwartz

nandaschwartz@comcast.net

(925) 932-3477

The Horseless Carriage Artwork of Ben Sharpsteen

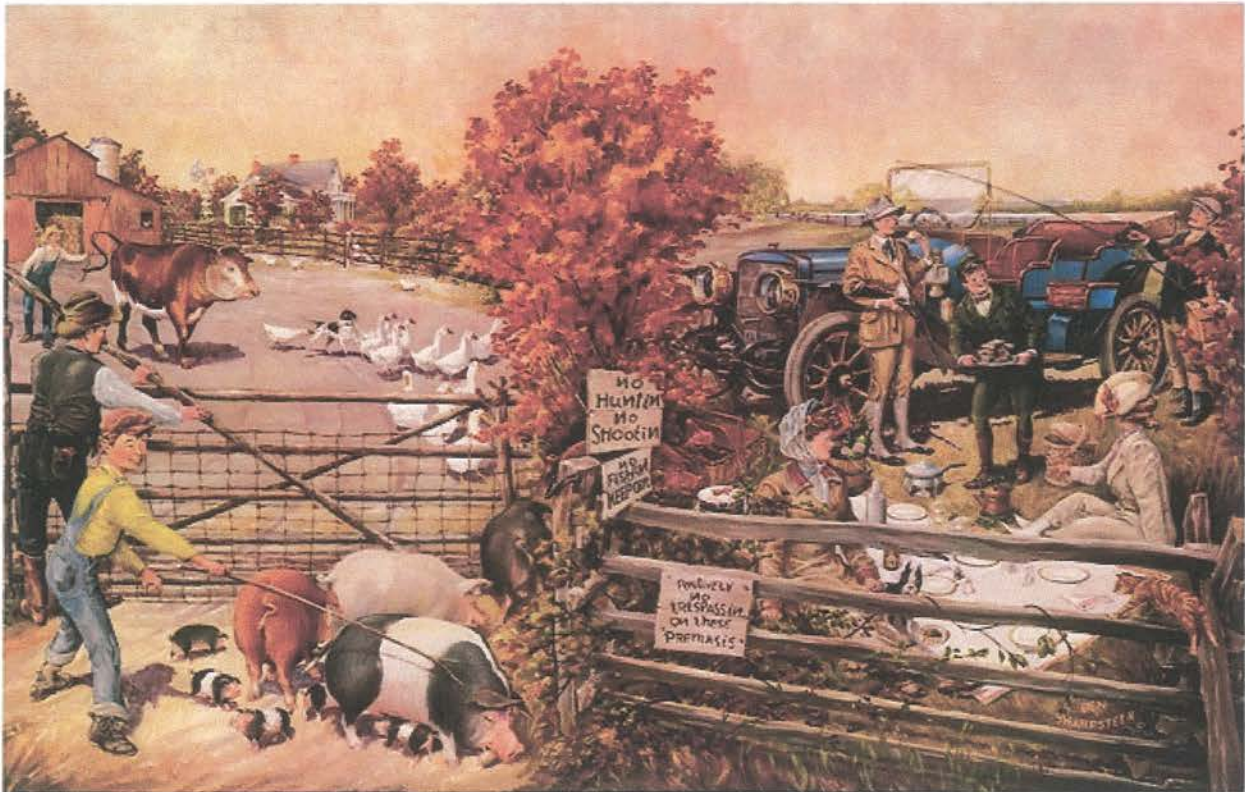

"Lozier and the Picnic" from *Horseless Carriage Gazette*, January-February 1970

Courtesy Sharpsteen Museum

Ben Sharpsteen grew up during the early days of the automobile. Ben first visited his grandmother's farm in Calistoga in the summer of 1903. Ben would spend every succeeding summer there, up to and including 1915, when he was 20 years old. It was in Calistoga that Ben would develop his love for the country life, and the automobile. Ben would eventually find his way to the Disney Studios, where he would make movie history, only to eventually give it all up and return to his beloved Calistoga.

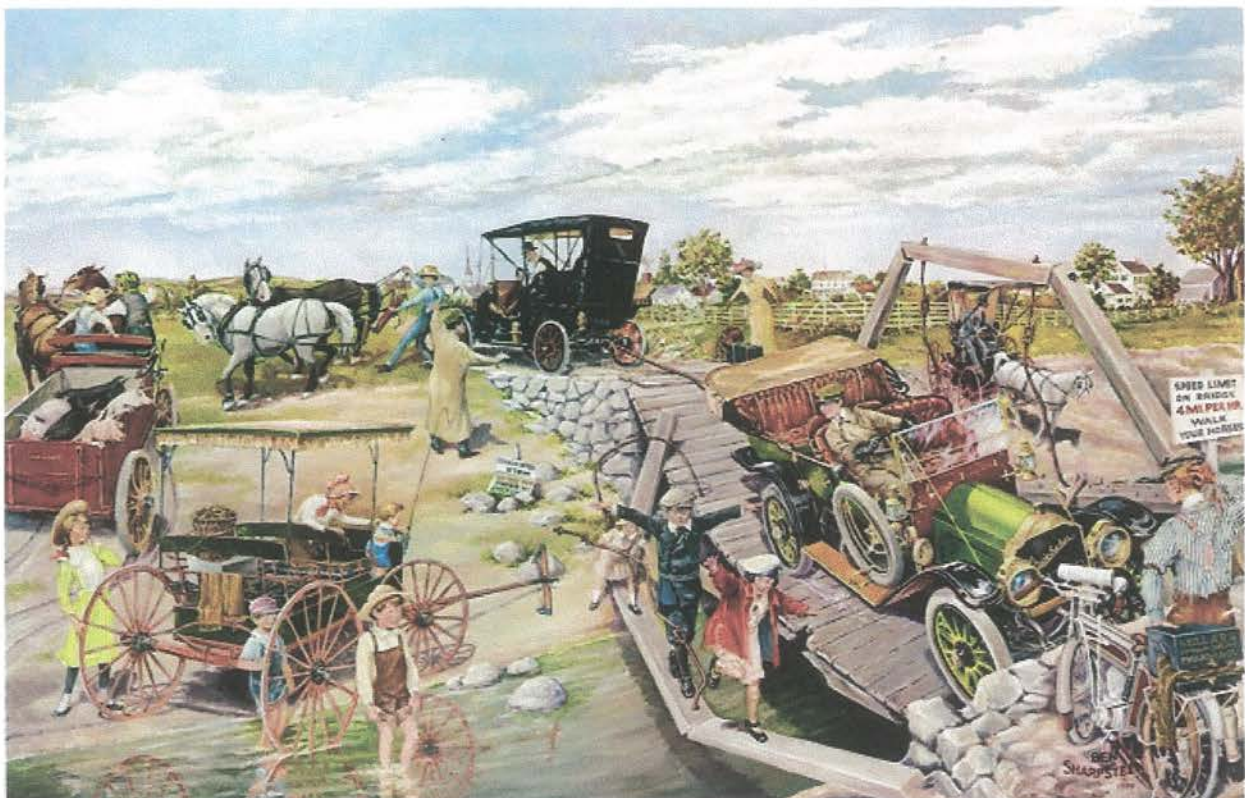

"Studebaker-Garford & the Broken Bridge" from *Horseless Carriage Gazette*, May-June 1969

Courtesy Sharpsteen Museum

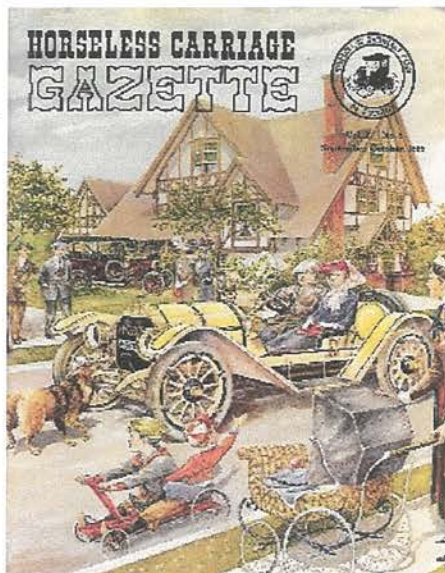

Ben's Artwork appeared on 19 front & back covers of the "Horseless Carriage Gazette" from 1964 to 1975



Ben spent 33 years with Disney Studios, from 1929 to 1962. Ben began his career with Disney as an animator, but went on to make many classic Disney films. The Disney films that listed him as either producer or director included: *Pinocchio*, *Dumbo*, *Fantasia*, *Snow White*, *Cinderella* and numerous nature films, including *Bear Country*, *The Living Desert*, *Beaver Valley* and others.

Ben (right) with an unidentified Disney employee
(Just kidding! . . . of course, that's Walt Disney)

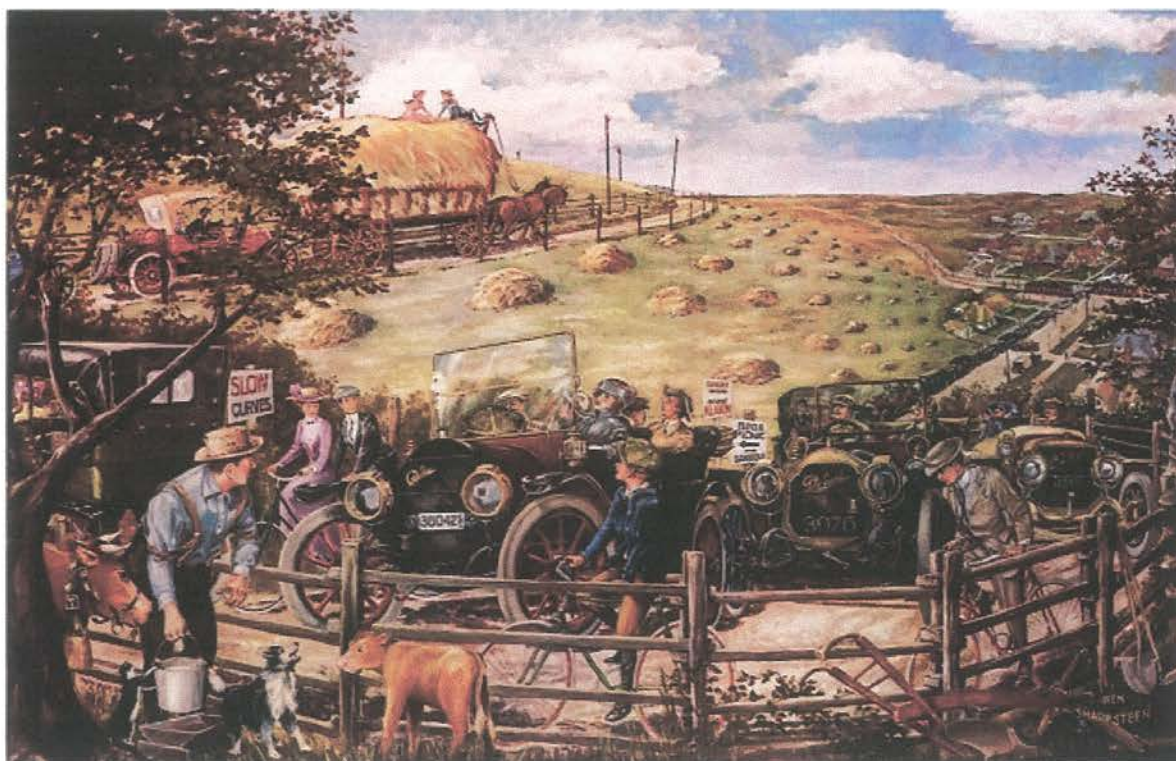

"Hayride with Cadillac, Packard and Lozier"
from Horseless Carriage Gazette, January-February 1969

Courtesy Sharpsteen Museum

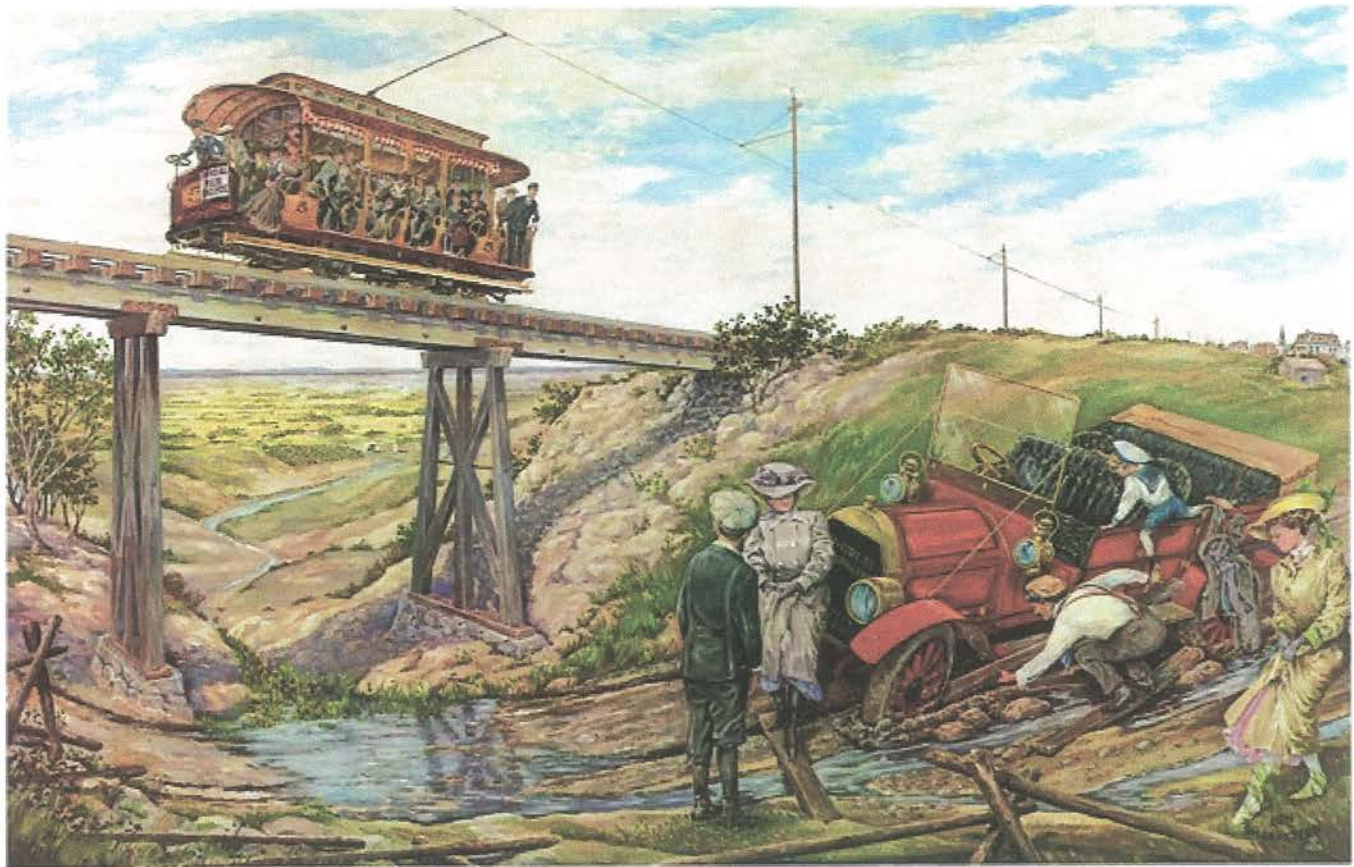

"Trolley Car & 1908 Great Arrow" from Horseless Carriage Gazette, January-February 1974

Courtesy Sharpsteen Museum

HORSELESS CARRIAGE DAYS



From the brush of Ben Sharpsteen- created from his own memories of a by-gone era. Historically authentic, accurate in detail, abounding in human interest, and filled with more incidents than first meet the eye!

These 11"x17" full-color reproductions of Ben's series of 19 large paintings (some currently on display in the Special Exhibit "Early Automania") on heavy stock paper are suitable for framing and are also available laminated- perfect for use as placemats! Make great gifts!

Only \$5 each (\$7 laminated). Available exclusively in our Museum Gift Shoppe.

Mail and telephone orders welcome (postage and tax will be added).



Ben tinkering with his 1909 Paterson

About
Ben Sharpsteen

Second Impressions

Sharpsteen Museum Reprints

*Want to
learn more?*

"About Ben Sharpsteen" is available at the Museum

Changing a Lightbulb the old-fashioned way, from atop a Model T Ford



Courtesy of Muriel Lundquist

Horseless Carriage Cartoons From The Past

THE TICKMOBILE

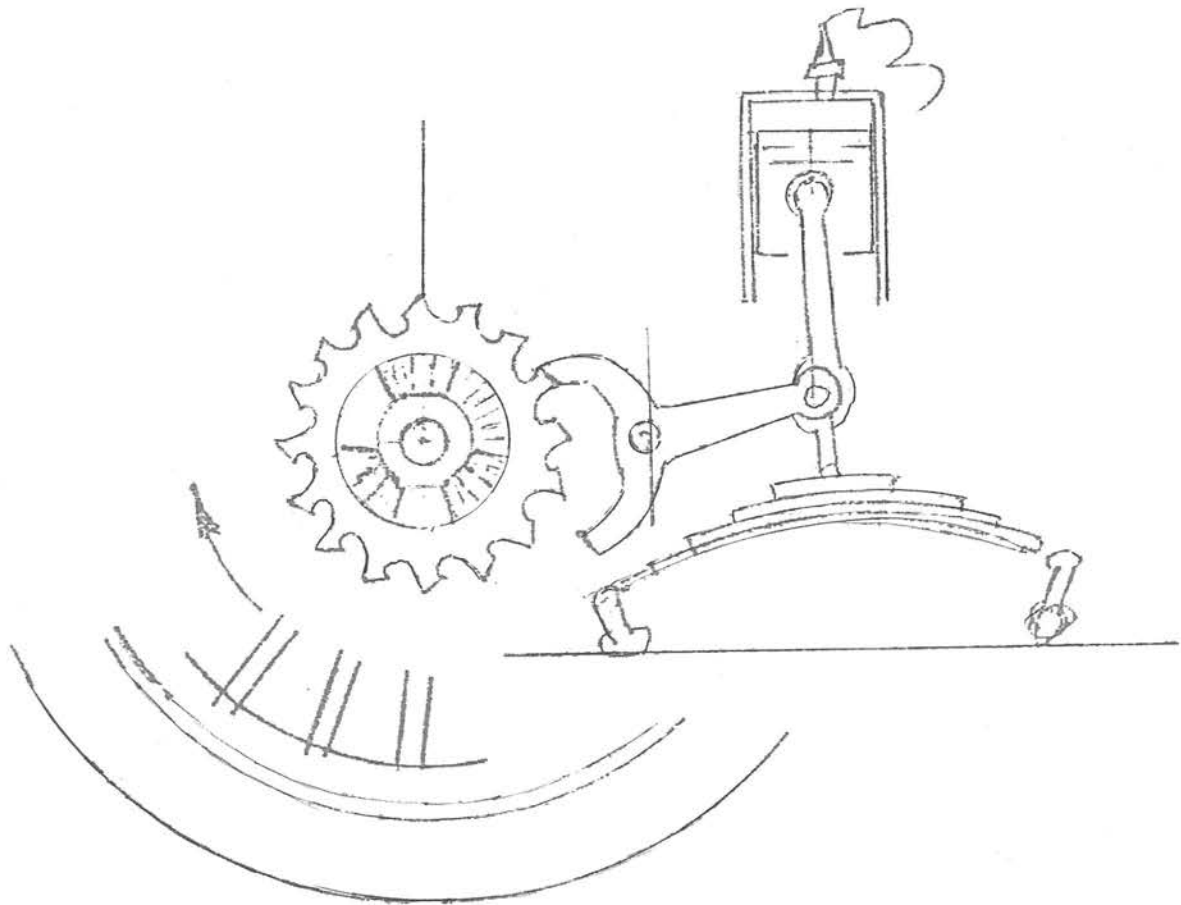

In the year 1907, the steeple clock in the type of a giant wagon spring clock disappeared from the Santa Clara Village church and in a few months time, Messrs. Max Koby and Ed Anderson came upon the scene driving the Tickmobile. They vowed the pilferage of afore said clock was none of theirs, as the alter boy had recognized portions of the car as that of the steeple's clock.

Public pressure was applied to the two suspects and the clock was restored in 1912.

(from the files of the Santa Clara Historical Society, H. D. Lundell, President)

I recently told Mark Cerruti about some cartoons I still had copies of that were mostly done by the late Bud Lundell, long-time BAHCC member who brought our club lots of laughs because of his wit and uniqueness. Mark checked them out and decided he would like to re-run them over time for your enjoyment.

Each cartoon was designed to poke fun at one or more other members, achieved by Bud's "inventing" and drawing a car that these other members supposedly owned. The first cartoon in the series was called "The Tickmobile," which Bud alleged was a car built and owned by fellow horseless carriage hobbyists Max Toby and Ed Andersen, who were at that time members of what was called the San Francisco Regional Group (a neighboring group that later was abandoned). The Tickmobile cartoon, printed above, was especially funny because the two of these guys were also known as antique clock collectors and restorers.

-- John Morrison



The G. & J. Tire of To-day

Represents the highest development in the art of tire manufacture. : : :

Vulcanized in one operation with low temperature and long heat : : :

Enhancing the quality of the rubber and preserving the full strength of the fabric. : : : : :

Cured in the open steam

Eliminating the possibility of scorching the fabric. : : : : : : : : :

Strong, Tough, Durable, Resilient. : : : : : : : : :

Write us for full particulars.

G & J TIRE CO.

Factory:
INDIANAPOLIS.

DEPOTS:

Chicago	Detroit	Boston	Buffalo
Cleveland	Denver	San Francisco	Philadelphia

DISTRIBUTING AGENCIES:

Minneapolis	Plant Bros.
Denver	
Los Angeles	Ramsay-Hutchins Rubber Co.

The Best Lamps are Solar Lamps

They are the acknowledged Standard Lamp of the Automobile trade—Standard because of their adoption by 20 American motor car manufacturers who equip with Solars to the exclusion of all others.

See that your 1909 car carries Solars!

Solar Lens Mirror Projector



898 8-inch Lens Mirror
Each, \$25.00

Solar Lens Mirror Searchlight

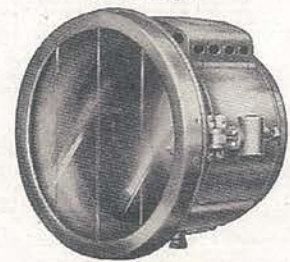

958-A 8-inch Lens Mirror
Each, \$15.00

Badger Brass Manufacturing Company

A Sneak Peek

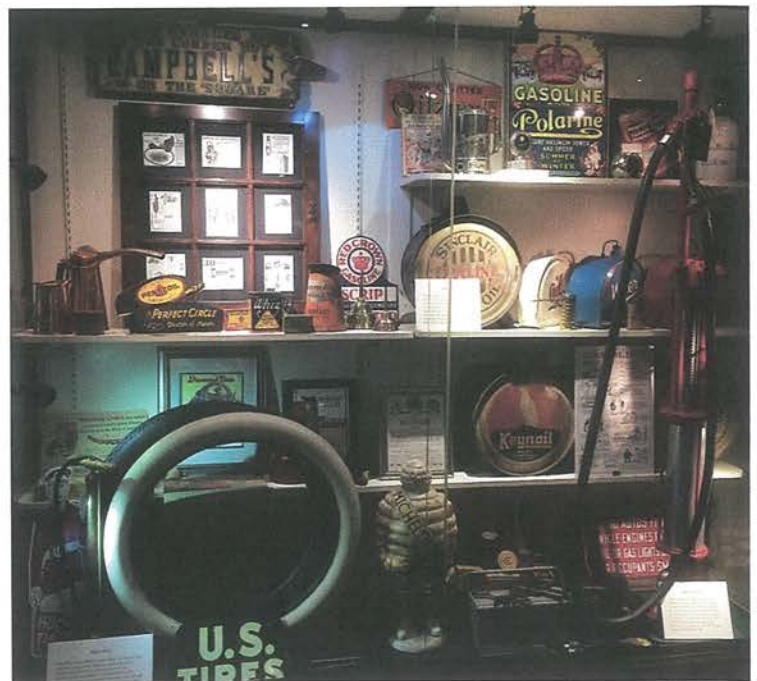

"Life In The Slow Lane" at the Sharpsteen Museum



BAY AREA HORSELESS CARRIAGE CLUB Holiday Dinner - Dance & Installation

Wednesday, December 12th, 2018

Cocktails 6:30 Dinner 7:00

Featuring Mr. Ron Sparzo on the Tyros 4 Keyboard with festive Christmas & Dancing Music

Traditional Holiday Dinner

→ Please bring your own dishes & table service ←

\$25.pp Members, \$35.pp non-Members & Guests

Guests Welcome!

!!! SANTA WILL BE COLLECTING GIFTS !!!

Please bring a new, unwrapped gift for Children's Hospital.

You may bring gifts early to the November meeting, or drop off at John & Carolee's house if you will miss the Party.

If you would enjoy decorating a table, please contact Carolee



RESERVATIONS DUE BY DECEMBER 1st!

Call Carolee Morrison @ 510-407-1186
or John Morrison @ 510-407-0708

Or Email: johnpmorrison@sbcglobal.net

Or mail your check payable to BAHCC to:
Whitney Haist, 12 Sunrise Hill Rd, Orinda, CA 94563

Hospitality Calendar

Dessert Sign-ups

November	Potluck - By alphabet, check Gazette
December	Holiday Party - Catered
January 2019	Donna Jones
February	L. S. Elliott
March	<i>Your name here!?</i>
April	Potluck - By alphabet, check Gazette
May	
June	
July	4th of July Picnic
August	
September	
October	
Contact Pam Johnson or Kaaren Brommer to Sign-up!	

Happy Birthday!

Ken Billingsley	Nov 1
Pam Johnson	Nov 7
Linda Pearson	Nov 11
Nancy Byl	Nov 12
John Vitale	Nov 15
Tony Wollesen	Nov 15
Chet Caldeira	Nov 17
Cheryl Guzzetta	Nov 19
Newell Booth	Nov 23
Steve Hoffman	Nov 27

Happy Anniversary!

Johnny & Christine Crowell	Nov 18th, 1995
Robert & Kelly Stone	Nov 19th, 1995
Paul & Carlee Bittner	Nov 23rd,
John & Carolee Morrison	Nov 27th, 1982



Travels with George

and the Great Places to Eat in the Gold Country

One of my favorite places to go to up in "gold Country" to go up to Ca State rt. H'way 49, to Jackson. Then down to Angels Camp where I like to stay. I found two excellent places to eat.

Camps Restaurant that is part of the Green Horn Creek Resort and golf course, at the town of Angles Camp. The building looks like a large green house (think of the greenhouse in SF golden gate park) Dining is inside and out. As you come in, they have a good size separate room that looks to hold 50 plus people.

I am sure that they would love to have a car show photo shoot, with the building and golf course... I think that the National may also want to a part of it.

The other special place is the "The 1859 National Hotel and Restaurant" in (old) Jamestown. Remember there are two parts of Jamestown 's of each other and this is where the steam trains are and the Calif rail park...

The bar and restaurant dates to the 1859 and you get the feeling of what the gold rush miner's felt...

PS... The hotel has a ghost, a young lady looking for her husband who was shot and killed coming down the stairs by a drunken miner. So the kitchen help working late say !



Camps Restaurant



Camps Restaurant at Greenhorn Creek resort offers award-winning dining, with a menu that highlights the comfort of tradition, along with the flair of contemporary cuisine, accentuated by local, seasonal ingredients. Service is extraordinary, executed gracefully, and is only matched by the warmth and friendliness of the staff. Camps has a carefully curated wine list featuring many of The Sierra Foothills' local wineries, boasts a bar that is abuzz with an exciting array of specialty cocktails, and an excellent selection of draft beers. The restaurant features an elegant main dining room, an outdoor patio, and a more intimate dining experience in our Mark Twain Library. The grounds are appointed with Bocce Ball Courts and the Wisteria Arbor, is perfect for weddings and outdoor events, and it is all nestled amid one of the most picturesque settings in the Sierra Foothills.

TRAVELS WITH
GEORGE

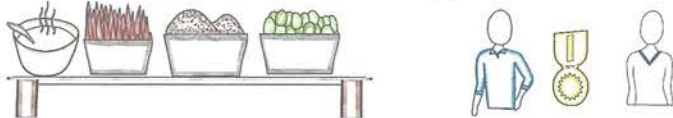

BAHCC Club Meetings Calendar

Managed by Ed Harley, V.P. epharley@pacbell.net 925-838-7460

Month	Date/Day	Events	Speaker/ Special Event
Nov 2018	Nov 7 - Wed	Club Meeting	<p>Pot Luck Dinner and Member Appreciation Night</p>  <p>Bring food and eat food at our Fall Potluck. Also Member Appreciation Night and the BAHCC 2019 Board Member Nominations; Membership Vote</p>
	Nov 9 - Friday	Sharpsteen Museum Calistoga, CA	<p>Grand Opening of the BAHCC Automobile Display at the Sharpsteen Museum in Calistoga from 5:30pm to 7:00pm.</p> 
	Nov 14- Wed	BOD Meeting	BAHCC 2019 Board Officer Nominations and Election - Brass Door Restaurant, San Ramon
Dec 2018	Dec 12 - Wed	Holiday Party	<p>Dinner & Dancing John and Carolee Morrison will be our gracious hosts for the Holiday Party, something they have done for more than 20 consecutive years. Come enjoy a catered dinner, music, dancing, Santa, and good cheer. BAHCC 2019 Board Officers Installation</p> 
Jan 2019	Jan 2 - Wed Jan 16 -Wed	Club Meeting BOD Meeting	
Feb 2019	Feb 6 - Wed Feb 20-Wed	Club Meeting BOD Meeting	
Mar 2019	Mar 6 - Wed Mar 20 Wed	Club Meeting BOD Meeting	
Apr 2019	Apr 3 - Wed Apr 17 -Wed	Club Meeting BOD Meeting	Potluck Dinner and Auction
May2019	May 1 - Wed May 15 -Wed	Club Meeting BOD Meeting	
Jun 2019	Jun 5 - Wed Jun 19 -Wed	Club Meeting BOD Meeting	
Jul 2019			NO METTINGS
Aug 2019	Aug 7 Wed Aug 21 Wed	Club Meeting BOD Meeting	Member's Hobby Night
Sep 2019	Sep 4 Wed Sep 18 Wed	Club Meeting BOD Meeting	
Oct 2019	Oct 2 Wed Oct 16 Wed	Club Meeting BOD Meeting	



BAHCC Tour Calendar Club events Bolded

Managed by Johnny Crowell, Tour Director. Jcrow22006@aol.com 925-963-5835

Month	Date/Day	Events	Tour Leader	Details
Nov 2018	Nov 10 th	Sharpsteen Museum Tour	Vince O'Brien	An informal one-day tour Tour commences @ 10am at the Best Western 1830 Lincoln Avenue Calistoga (Plenty of trailer parking there) Contact Vince to let him know you're coming! 415-302-7030 vob_low@comcast.net
	Nov 23rd	Pilgrim's Picnic & Backroads Tour	Norman & Adria Schwartz	Day after Thanksgiving in Martinez (see Flyer for details)
				Have an idea for a good tour? Call Johnny



BROWN-LIPE PRODUCTS

Highest Quality

DIFFERENTIAL GEARS
by BROWN-LIPE-CHAPIN COMPANY
TRANSMISSION GEARS
by BROWN-LIPE GEAR COMPANY

BOTH FACTORIES

H. W. Chapin, Gen'l Mgr. SYRACUSE, N. Y.



Sheet Metal Stampings

Axle Housings, Brake Drums,
Torque Arms, Hub Caps and Flanges,
Ball Cups and Retainers,
Step Hangers, etc.
for Pleasure Cars and Motor Trucks.

The Bossert Company
UTICA, N. Y.



BAHCC General Meeting Minutes from October 3, 2018

Call to Order—President Ed Archer called the meeting to order at 7:37 p.m. There were no guests to introduce. Ed noted that again at this meeting there were numerous members without name badges, and he reminded that members need to please remember to wear them as a courtesy to new members and guests.

Approval of Minutes—Ed asked if there were any corrections or additions to the draft of the 9/5/18 minutes that were printed in the October issue of the Gaslight Gazette. Don Azevedo noted that the September meeting's treats had been provided by Chris Crowell, not by Joyce Azevedo, and then the minutes were approved with that correction made.

Health and Welfare—John Morrison reported that member George McCrumb was absent tonight because he had been accidentally hurt and was recovering in a rehab facility in San Leandro. Tony Wollesen added that Santa Clara Valley fellow car hobbyist Chet Zimmerman, whom many of us have known for many years, had passed away recently at age of approximately 97.

Treasurer's Report—Treasurer Whitney Haist said all accounts are balanced and in good order.

Tour Chair Report—Johnny Crowell asked for reports of progress that members could share regarding the upcoming Ben Sharpsteen Museum display our club is working on. Vince O'Brien shared ideas he has been thinking about for a tour or gathering to take place along with the opening of the display. Ideas were described and pros and cons or questions were added as food for thought. Don Johnson said maybe Doug Durein (not present tonight) and the late Doug King had chaired a tour in the Calistoga area in the past, and that Doug Durein might have some good ideas for Vince. Vince said he will poll interest and gather more information. Kaaren Brommer cautioned that she had tried to line up lodging in Calistoga for the grand opening event and had been repeatedly told there was nothing known to be available.

Johnny asked if someone could report on the recent Antique Cars in History Park event. Ed Archer and others made comments about the event this year. It was again a very good event with a great many stock pre-1946 cars, and was very entertaining and successful again. John Morrison had brought three large round tables along with chairs and umbrellas for BAHCC use, but there was only a small number of our members in attendance. He noted however that numerous members of other regional groups joined us and a good time was had by all. Ed Archer said that no rent is charged by the City of San Jose for the use of History Park for this huge annual event, and he added that he was aware that one or more other car clubs

had therefore made donations to the City of San Jose in appreciation of this event, possibly something we could consider doing in the future as well.

Johnny also reminded us that the Schwartz family is again planning to have a Pilgrims' Tour in or near Martinez, one where everyone brings their Thanksgiving leftovers the Saturday after Thanksgiving.

Website Report—Don Azevedo reported that all of the proposed website updating is now completed and incorporated.

Gaslight Gazette Report—Editor Mark Cerruti said he would appreciate receiving more information about the upcoming Ben Sharpsteen Museum's BAHCC Display that he can incorporate into the Gazette.

Karen Archer asked about Ironstone. It was then reported that the Haists won a first place award with their Stevens Duryea, and that this year's Ironstone event was as good as or even better than ever. Apparently there was more to see and do of interest, including a series of antique car races on a dirt and gravel oval track they had made. Our own Ed Archer and quite a few other race car drivers participated in it, and for a price, members of the audience could purchase a ride in the "mechanic's seat" of some of the race cars, too. The race track was wet down by a water truck, making the rides even more exciting. Karen Archer said the passengers who paid for the rides seemed quite happy to be muddy; it was as though the muddy clothes became a "badge of honor!"

Unfinished Business—none

New Business—none

Adjournment—occurred at 8:40 to refreshments provided by the Harleys, although they were not able to be present. However, Mark Cerruti kindly brought them to the meeting.

Other—Bill Austen gave a very interesting talk about Ben Sharpsteen, his life as a Walt Disney artist, his creation of his museum, about his having been a longtime good friend to Bill, and about what an honor and pleasure that had been for Bill.

Respectfully submitted,

John Morrison, Secretary



BAHCC Minutes from the Board Meeting of 10-17-18

Call to Order—President Ed Archer called the meeting to order at 7:45 p.m. in Mark Cerruti's garage in Danville, CA.

Approval of Minutes of the Board Meeting of 9-19-18—These minutes were written by acting secretary Chris Crowell, and they were passed as printed at the BAHCC General Meeting of 10-3-18.

Membership—Don Azevedo reported that there was nothing new at this time.

Treasurer's Report—Whitney Haist said there had been no treasury activity since the last meeting.

Tour Report—Johnny Crowell noted the upcoming Pilgrims' Tour to be put on by the Schwartz Family the day right after Thanksgiving. There was also the mention of some possible activities surrounding the opening of the upcoming BAHCC's antique auto-related displays at the Ben Sharpsteen Museum in Calistoga. Some members reported having been able to find lodging in Calistoga at this time and that they did successfully awhile back. It was also noted that Vince O'Brien is still looking at the possibility of holding some form of club activity to coincide with the opening of the exhibit.

Website Report—Don Azevedo said Mark Wheeler, our webmaster, has completed all the items that he was asked to do.

Newsletter Report—Editor Mark Cerruti shared that the Schwartzes had sent him a full page announcement on the upcoming Sharpsteen Museum display. Mark has also found various other interesting materials that he is looking forward to including in the next and future gazettes.

Unfinished Business—Ed Harley noted that the next Board Meeting will be held at the Brass Door Restaurant on November 14th. The meeting was moved up by one week because the third Wednesday of November was felt to be too close to Thanksgiving. Ed Harley will send out an invitation to everyone concerned that will also include information about the four menu item choices that will be available, and all those coming will be asked to inform Ed of their preferences so he can communicate that to the restaurant.

Appreciation Dinner/Certificates of Recognition—The Board discussed the idea of this topic, and the consensus is that this is a very good idea. Continued discussion will occur at subsequent board meetings.

Filling 2 unfilled Board Positions—Don Azevedo said he has talked to several folks to try to fill them for 2019 and has now been able to do so. (Vince O'Brien and Jon Eugenio will be filling those two positions.)

Club Jackets project—John Morrison has been in touch with HCCA National Director Keene Brewer, who is currently in charge of merchandising for the HCCA. They too are looking for a source for suitable jackets for national club use but have not settled on anything yet that they like. Chris and Johnny Crowell said that they may have a source, and it was suggested that John Morrison and Don Azevedo send them photos of ones from the past that they could show to their contact person for more ideas. John and Don agreed to send photos to Chris and Johnny.

BAHCC Holiday Party—It was asked what help might be needed by Carolee Morrison regarding the Christmas Party. Carolee was not present, but John said she always likes help with decorating tables. Don Azevedo volunteered that he and Joyce would decorate one, so did Ed Harley, and so did the Crowells. John said Carolee will check with other members that have typically decorated tables and/or taken care of the bar in the past.

New Business—Mark Cerruti passed out copies of forms he made that will be mailed to all members as a reminder that dues will soon be due for 2019 BAHCC membership. They looked excellent. Whitney Haist said he would prefer them to be timed so that they are received near the end of the year rather than sooner so that he won't get flooded with checks before December 1st.

Next Meeting—As previously mentioned, the next board meeting is November 14th at the Brass Door Restaurant. And subsequently, the first board meeting of 2019 will be January 16th at John and Carolee Morrison's house.

Adjournment—occurred at 8:30 p.m.

Respectfully submitted,

John Morrison, Secretary

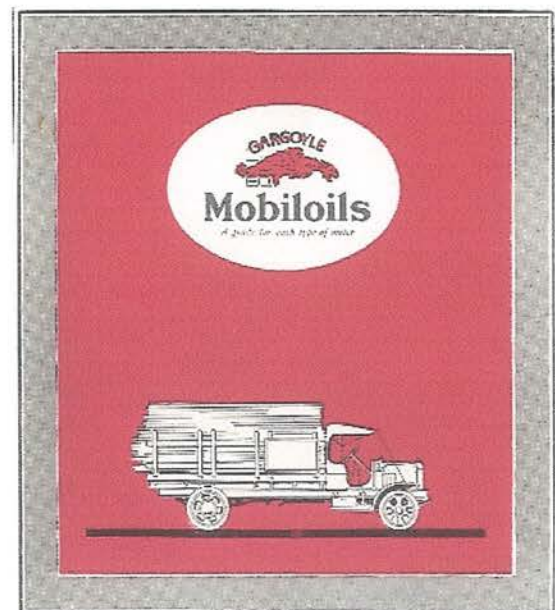



NO HUNTING

ROYAL MAIL MAILING ROUTE

MERPICIDE

CAUSTOGA 7

LAKEPO...

NO... SHERIF...

ADA...

SPRI...

20...

USM
C&CL
StageLine
W.S. PIERS
Propr.

CALIFORNIA